

D05Z1E7C4Z1H6-F 7(5x1)+(2x2x0,5)C

flat elevator travelling cable

material code

20209224

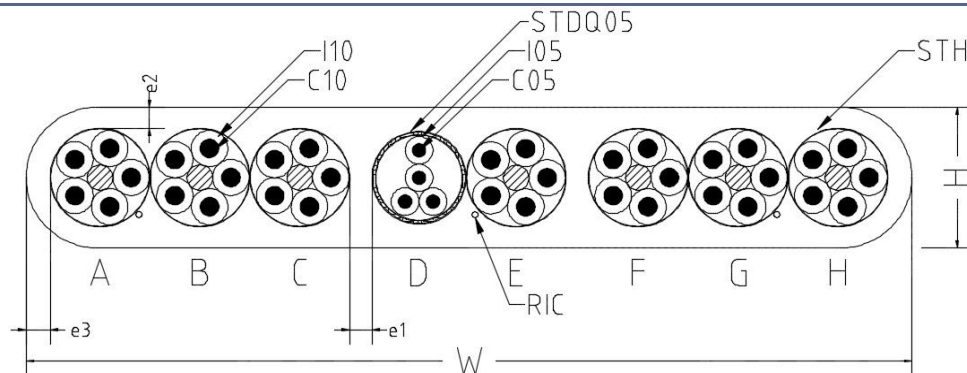

Construction

C05	Conductor 0,5 mm²	flexible stranded bare copper class 5
I05	Insulation	cellular polypropylene foamed with skin layer
C10	Conductor 1 mm²	flexible stranded bare copper class 5
I10	Insulation	special low smoke halogen free flame retardant thermoplastic compound
A, B, C E, F, G H	Strand	cores stranded around filler containment tape
D	Strand	cores stranded together to form pairs pairs stranded together to form DM quad STDQ05 separation tape braid of tinned copper wires 85% optical coverage containment tape
RIC	Ripcord	for removing sheath material
	Separation	talcum for elements - sheath separation
STH	Sheath	special low smoke halogen free flame retardant thermoplastic compound black similar to RAL9005 surface with knurling

Elements identification

Strand	Cores, color codes and numbers	Description
A	5x1 WH#1-5	white with black numbers
B	5x1 WH#6-10	white with black numbers
C	5x1 WH#11-15	white with black numbers
D	2x(2x0,5) RD+BU; GY+YE	red+blue; grey+yellow
E	5x1 WH#16-20	white with black numbers
F	5x1 WH#21-25	white with black numbers
G	5x1 WH#26-30	white with black numbers
H	5x1 WH#31-34+GNYE	white with black numbers+green-yellow

Cable marking

DRAKA 07 D05Z1E7C4Z1H6-F 7(5x1)+(4x0,5)C meter mark I order number

Repeated without meter mark in half of meter

Application

Flat, flexible travelling cable for use in passenger and goods lifts (elevators).

Electrical data

Element (type, cross-section)	Rated Voltage U0/U (V)	Test voltage core-core (V)	Test voltage core-screen (V)	Resistance (Ω /km)	Impedance @300 kHz (Ohm)
Power cores 1,0 mm ²	300/500	2000	-	19,50	-
Signal pairs/cores STDQ 2x2x0,5	100/100	1500	1000	57,20	120 +10% -15% abs. min 95

Technical data

Maximum Free Suspension Length m	Maximum Travel Height (approx.) m	Maximum Travelling Speed m/s	W	Cable Dimensions (approx.) mm					Standard Length m
				H	e1	e2	e3		
35	65	4,0	60,6 ± 4,0	9,6 ± 0,5	1,5	1,3	2,0	500	

Min. Bending Radius Static x cable height	Natural loop (Static Flexibility) mm	Operating Temp. Min. °C	Operating Temp. Max. °C	Standards	Rec. Suspension Device	Cable Net Weight (approx.) kg/km
15,0	550	-15,0	70,0	Similar to EN 50214	FCDS-3	870,0

Notes

REV 20180403